



Learn About 3D Printing

By Ben Egger
Digital Literacy Specialist

Upcoming Classes

- Defending Windows with Antivirus Software 6/26/18
 - 7:00 PM - 8:30 PM
 - Radmacher Meeting Room

- Introduction to iPads 7/10/18
 - 11:00 AM - 12:30 PM
 - Book Discussion Room

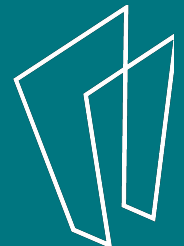

Classroom

- What is 3D Printing?
- Thingiverse - Download Files
- TinkerCad Introduction - Create Files
- 3D Print Demonstration



What is 3D Printing?

- There are lots of ways to make things
- 3D printing is when you use a computer to make a real world object

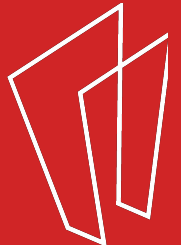

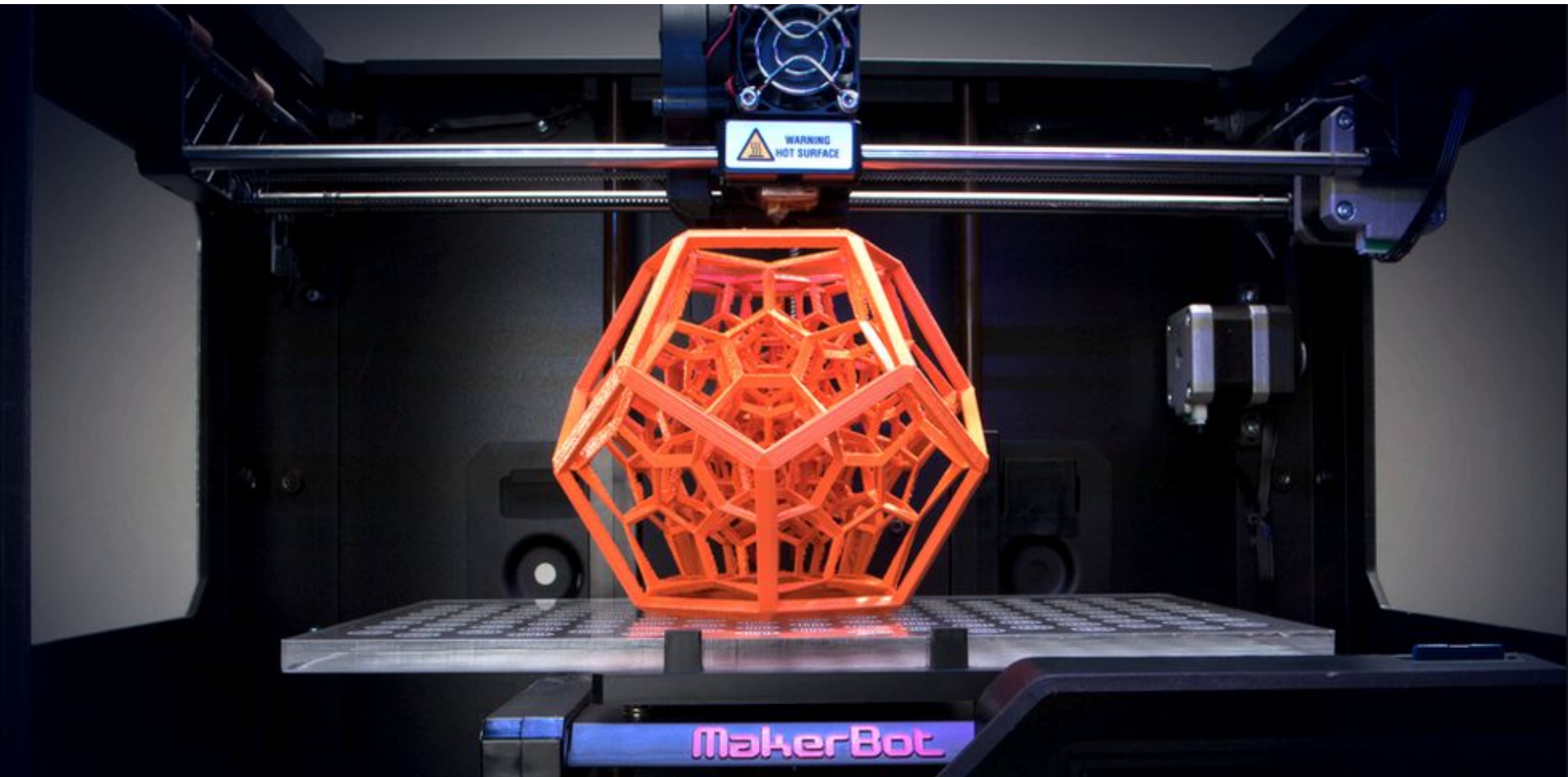

Printing with Plastic

- 3D Printers use a special type of plastic
- This is called **filament**
- The plastic is melted to very hot temperatures
- When it cools down, it becomes solid again
- PLA vs ABS



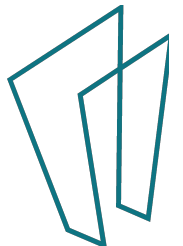

PLA vs ABS

ABS

- High melting point
- Printed on heated platform
- Toxic fumes; requires ventilation
- Used for car parts, prosthetics, legos

PLA

- Made from organic materials (cornstarch and sugar cane)
- Much lower melting point; may warp, crack, or melt under mechanical use and high temperature storage
- More for hobbyists

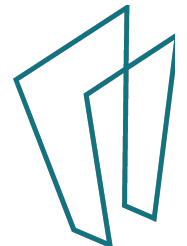



Where did 3D Printers come from?

- 3D Printing has been around since the 1980's
- Used in factories to make **prototypes**
- Allows companies to make sure their pieces and parts fit together before going into mass production

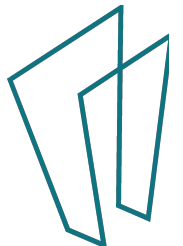

Additive Printing

- 3D printers draw very thin layers of melted filament with the nozzle
- A print job gets taller as layer after layer is stacked on top of each other
- One layer at a time

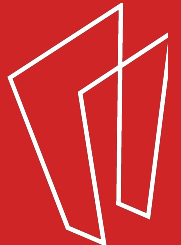

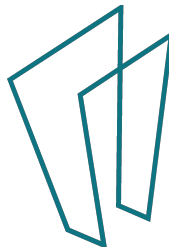
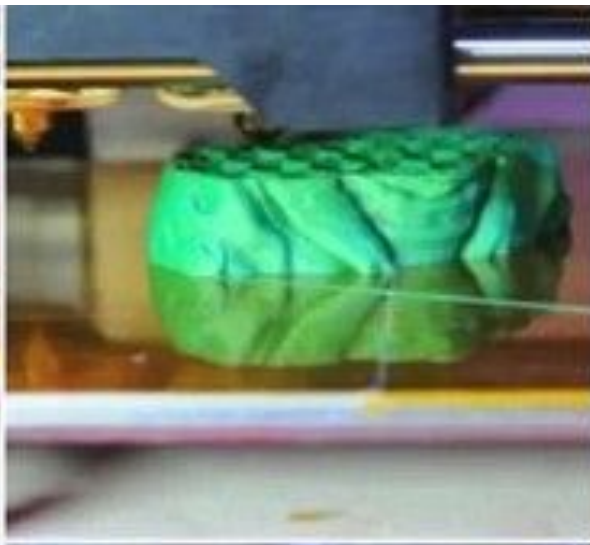
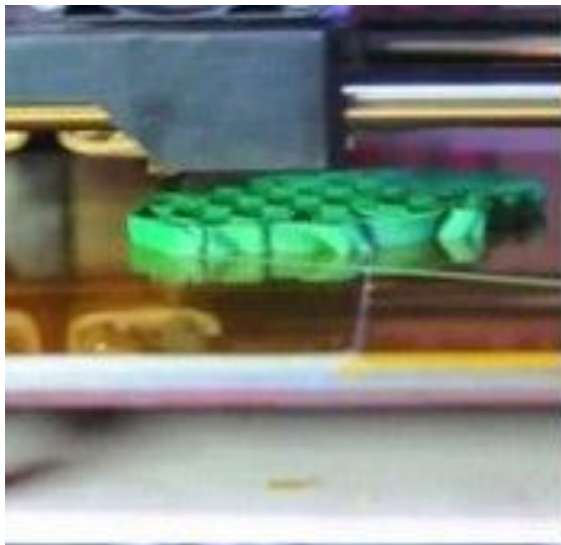

What can 3D Printers Make?

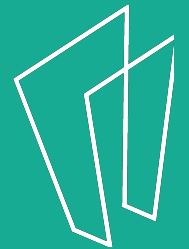



Toys

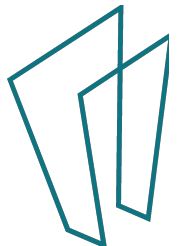



Toys

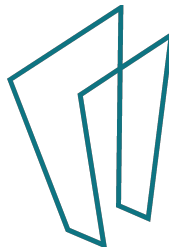



Tools

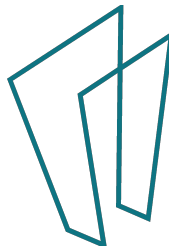



Tools

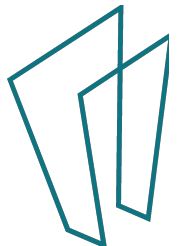



Cookie Cutters

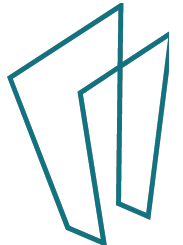



Light Switch Covers

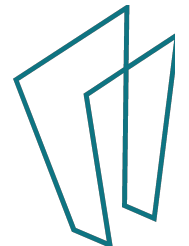

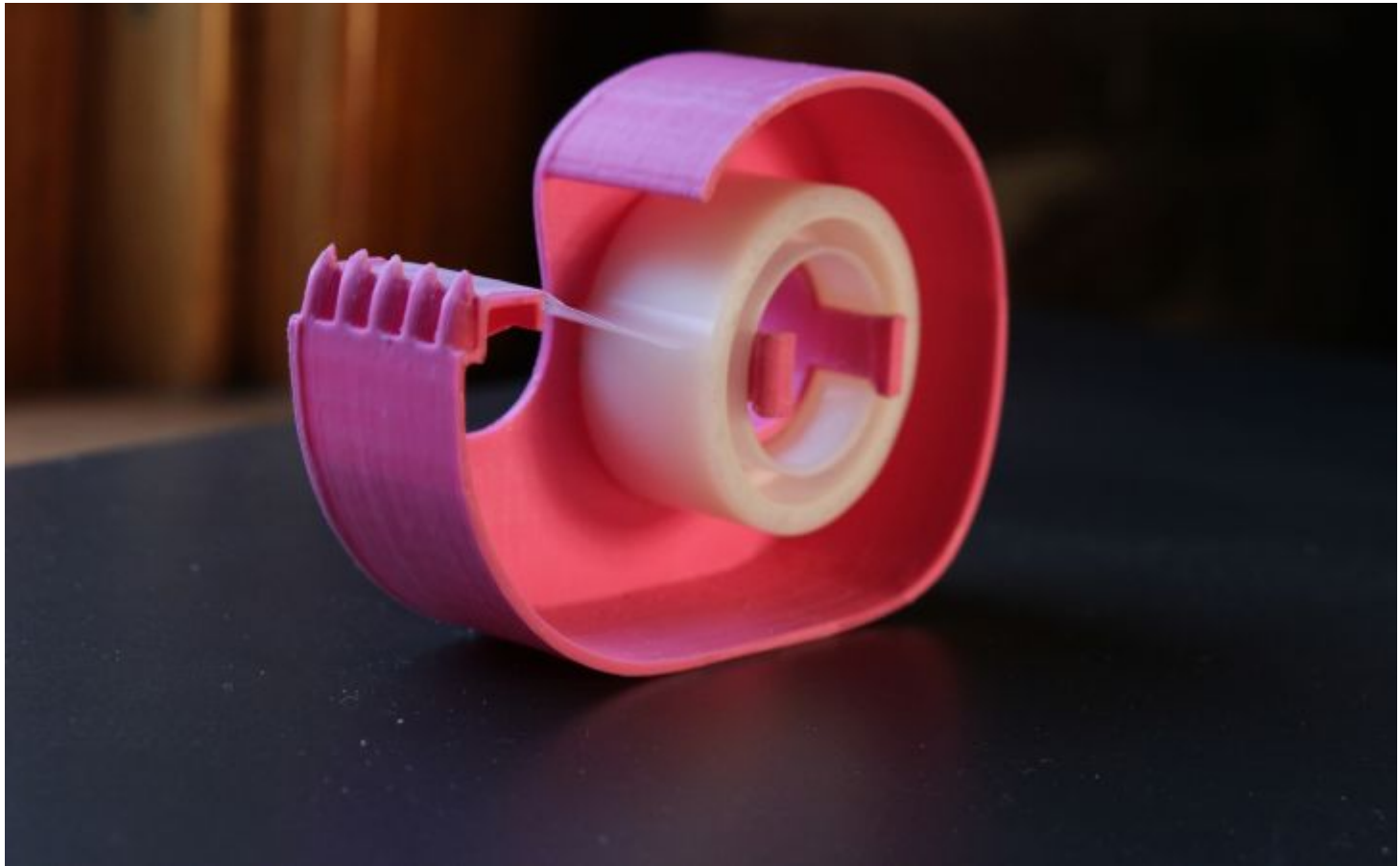

Tape Dispenser

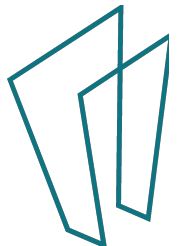



Prototypes

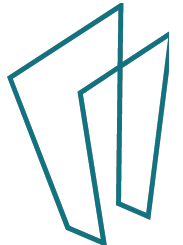



Prototypes

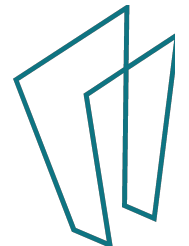



Prototypes

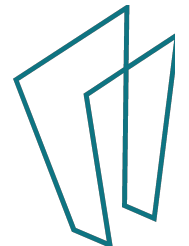



Prosthetics

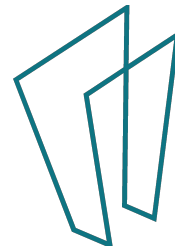



Prosthetics

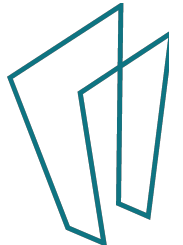



Food

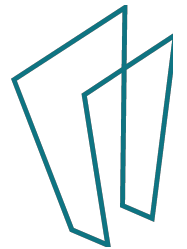



Food



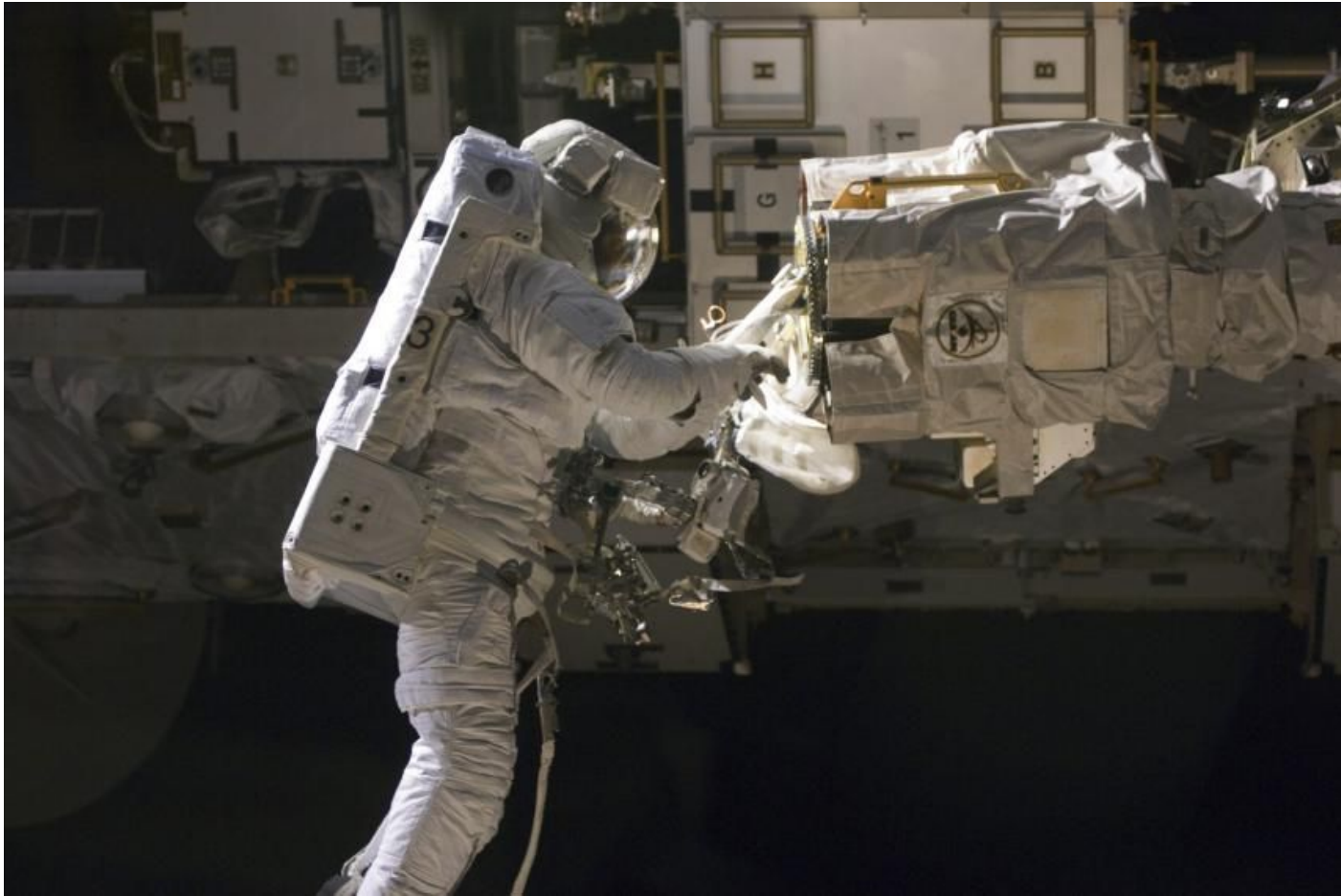

Isolated Jobs

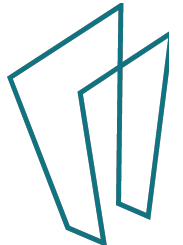



Isolated Jobs

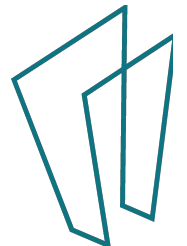

How do you make or find designs?

- 3D scanners
- 3D modeling software like TinkerCad
- Websites like Thingiverse.com

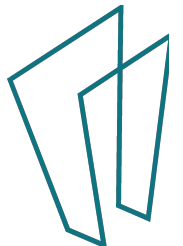



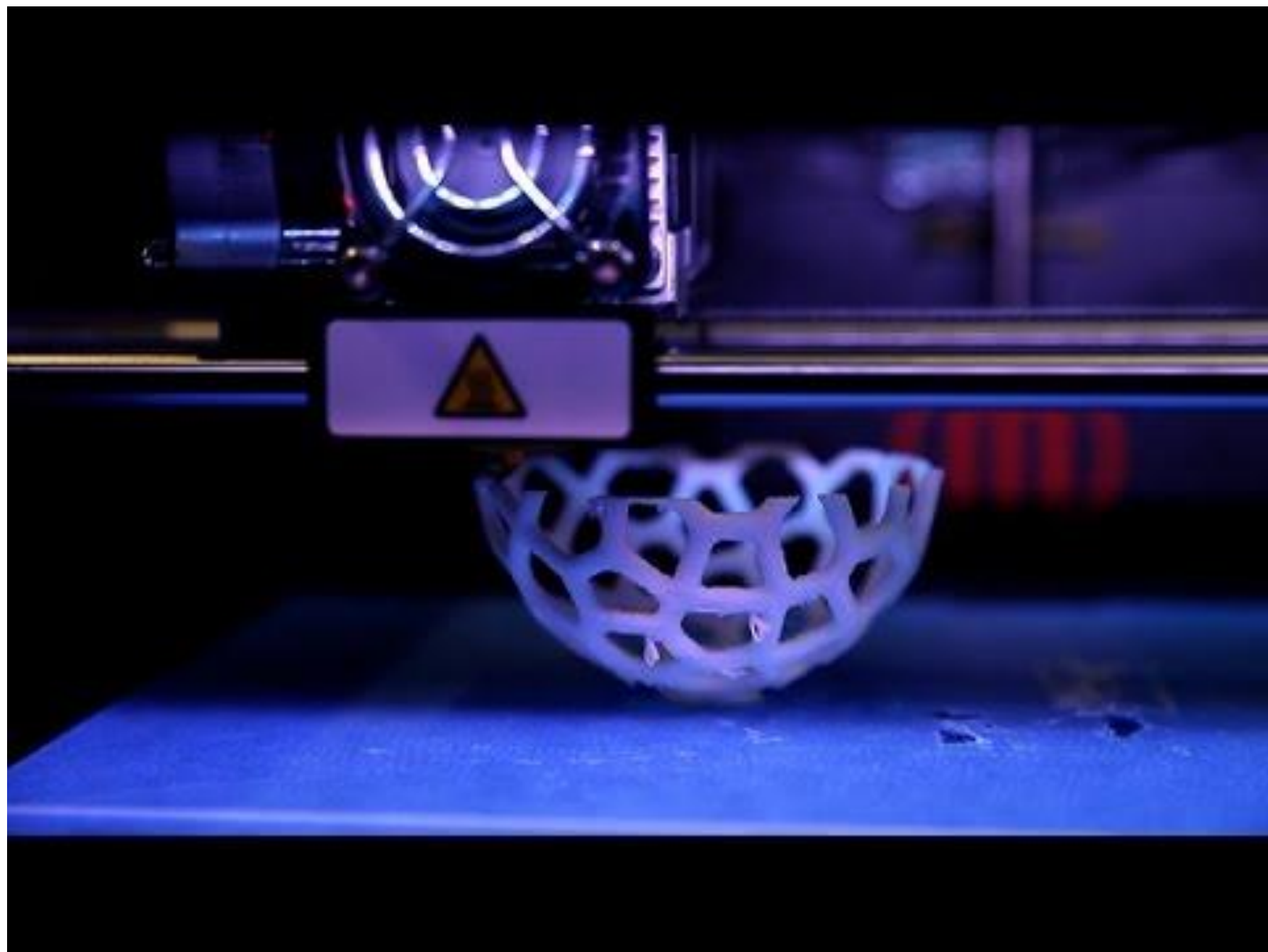

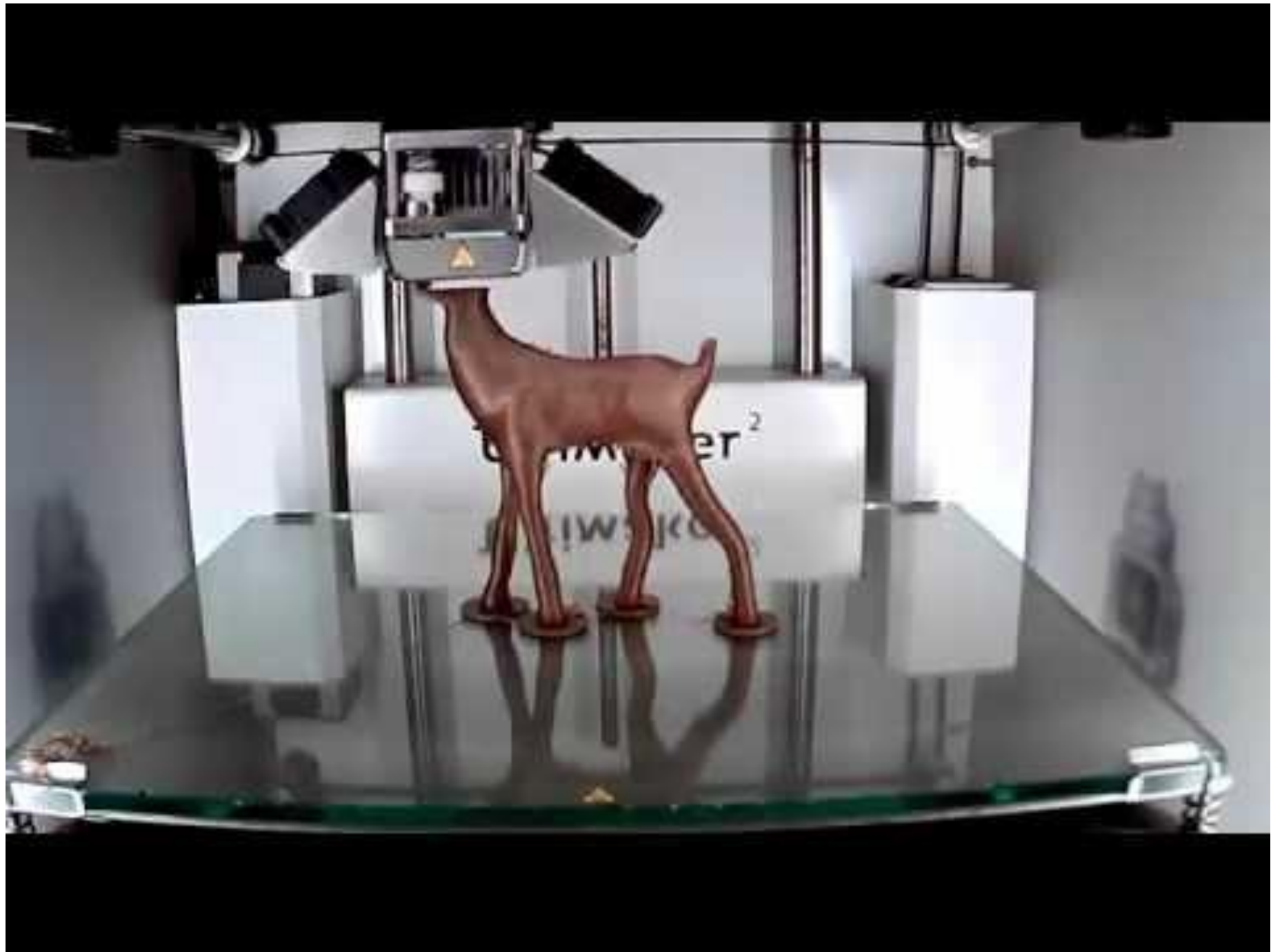

Failed Print Jobs



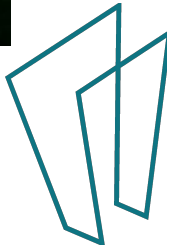

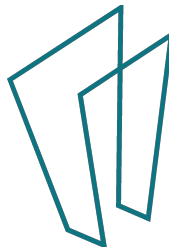

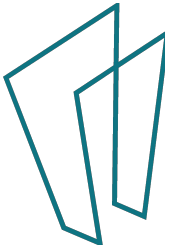

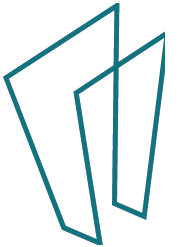



Questions?

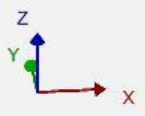
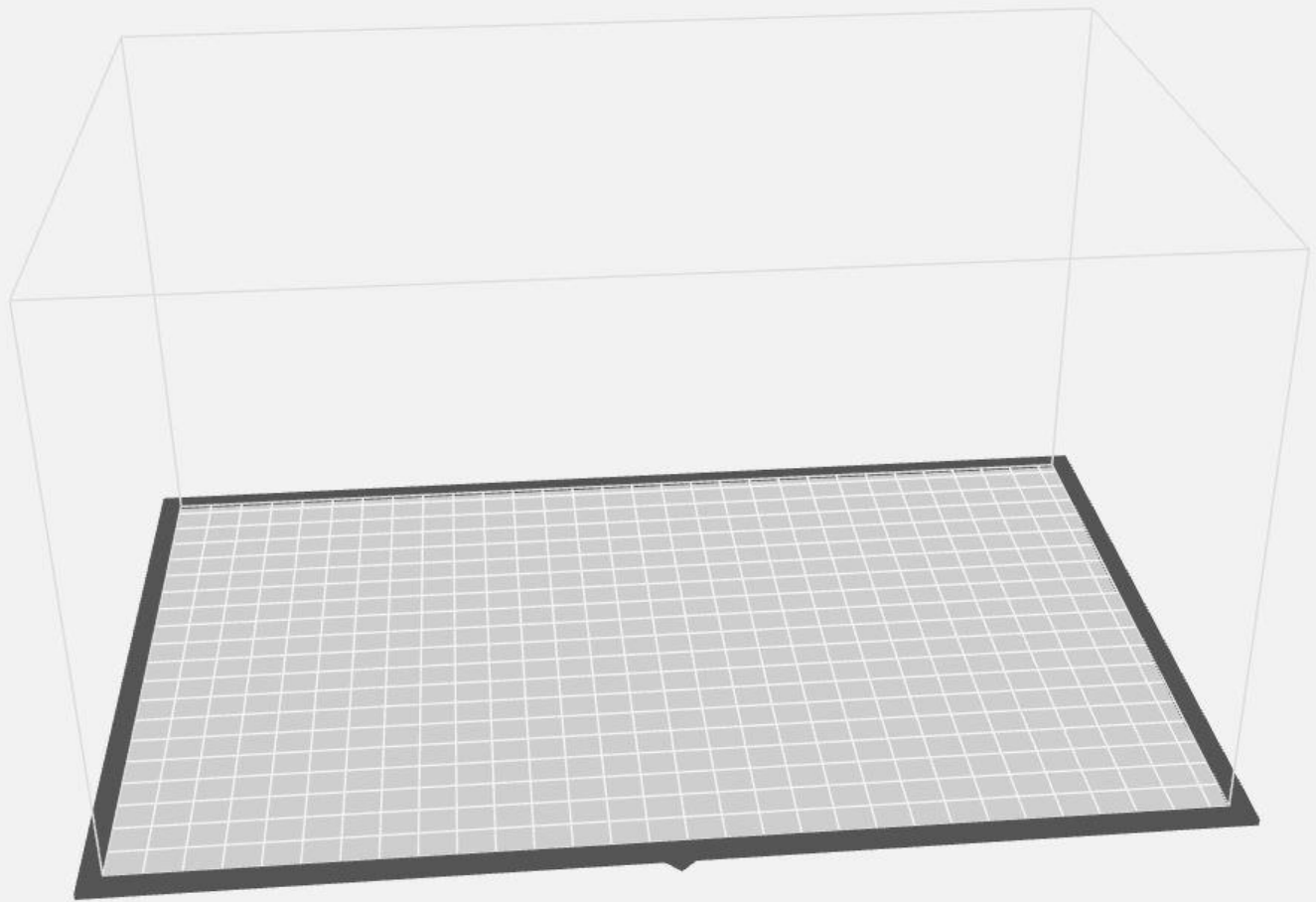

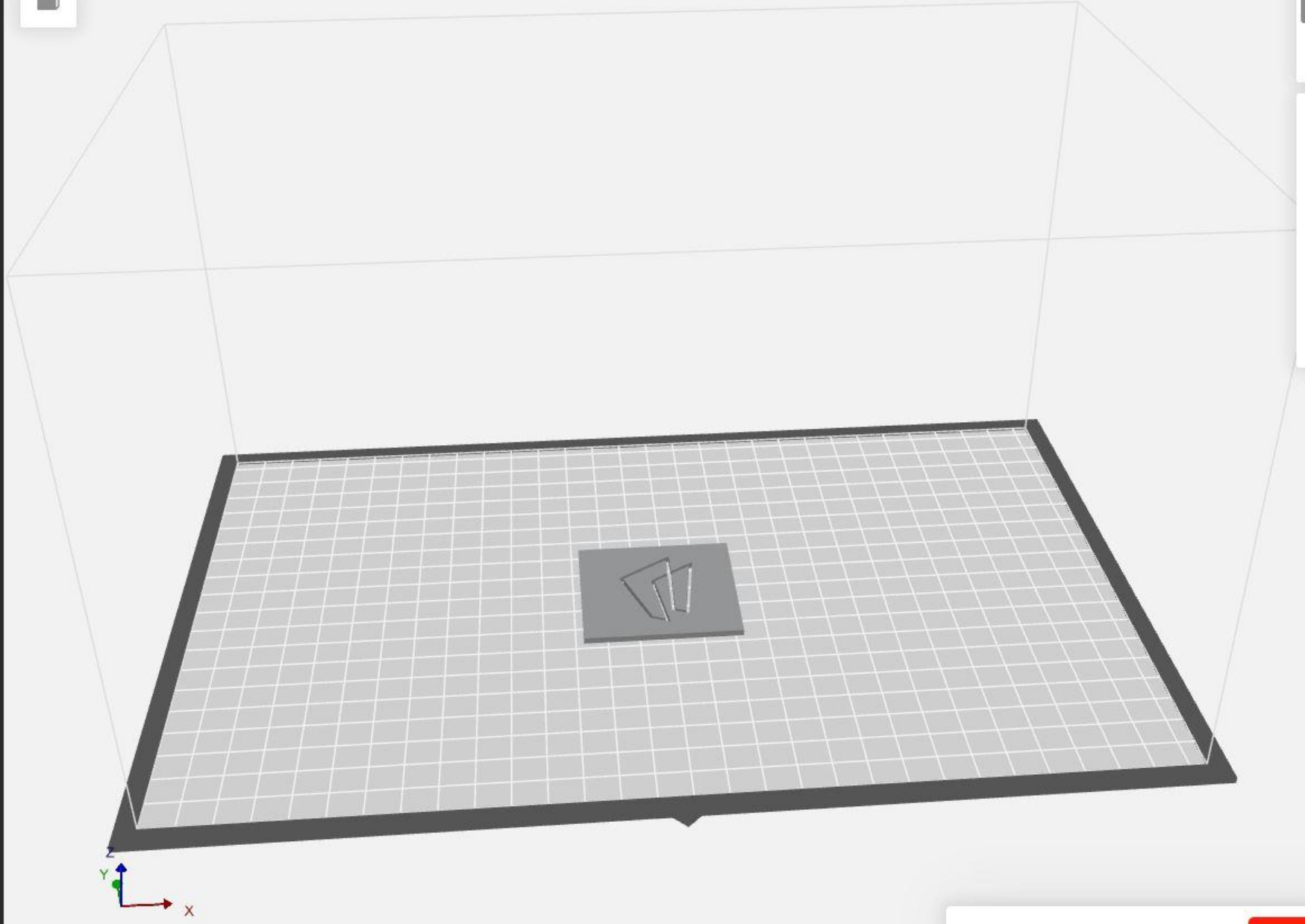

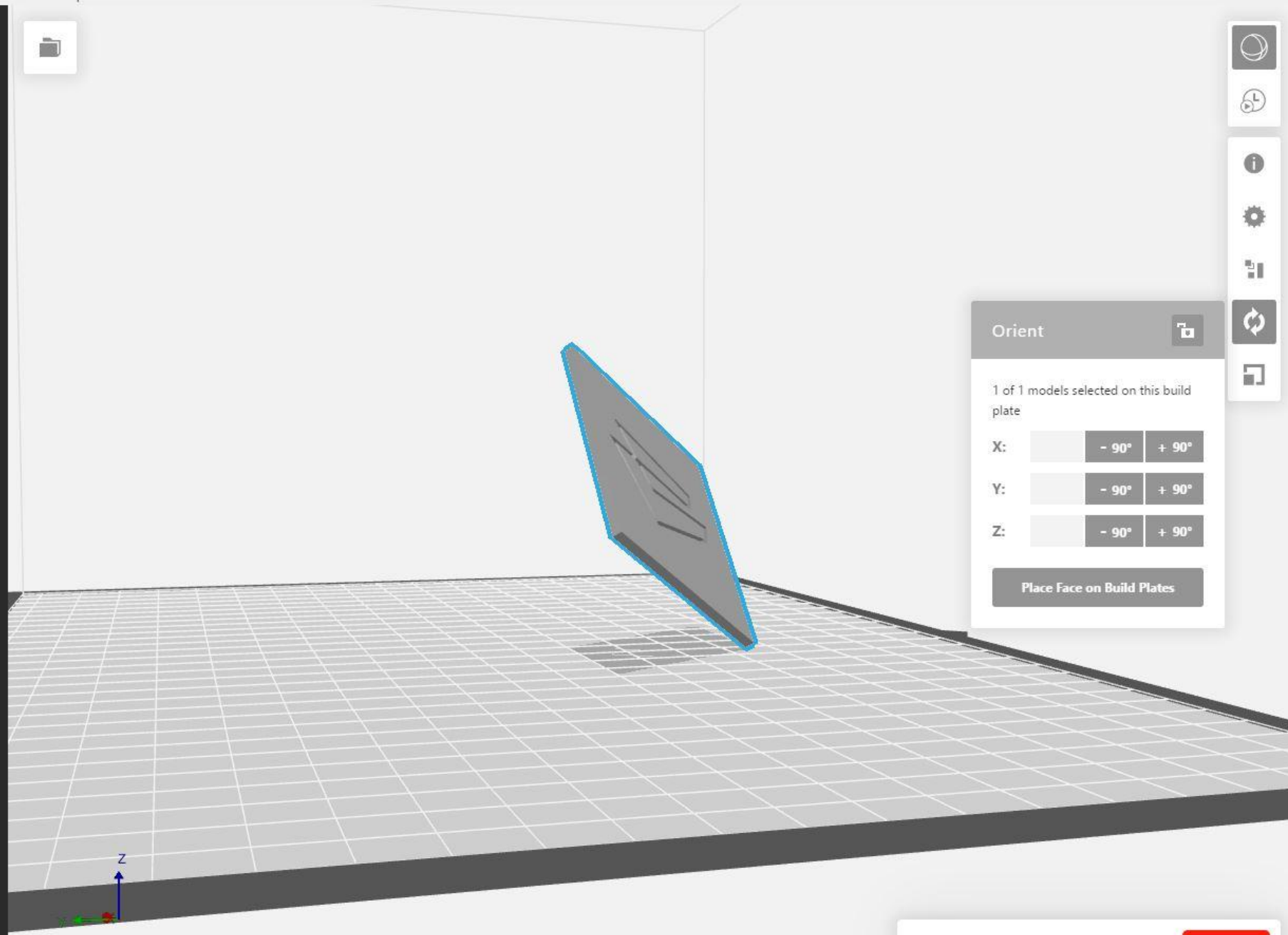



Orient 

1 of 1 models selected on this build plate

X:	<input type="text"/>	- 90°	+ 90°
Y:	<input type="text"/>	- 90°	+ 90°
Z:	<input type="text"/>	- 90°	+ 90°

Place Face on Build Plates

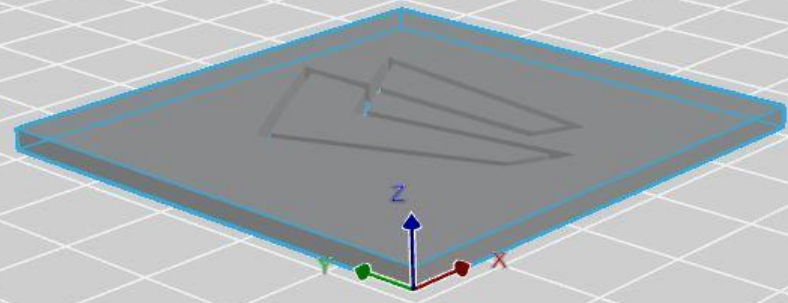

Scale

1 of 1 models selected on this build plate

Uniform Scaling

	%	mm
X:	<input type="text" value="100"/>	<input type="text" value="50"/>
Y:	<input type="text" value="100"/>	<input type="text" value="50"/>
Z:	<input type="text" value="100"/>	<input type="text" value="2"/>





Explore Thingiverse.com

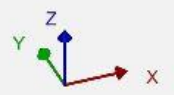
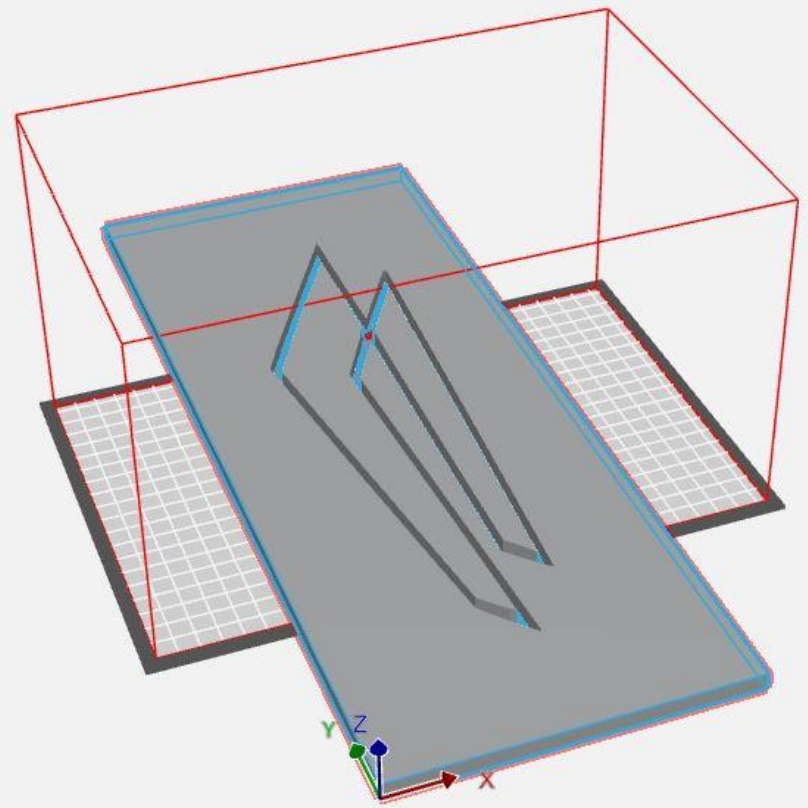

Scale

1 of 1 models selected on this build plate

Uniform Scaling

	%	mm
X:	347	173.5
Y:	900	450
Z:	400	8



Default Print Modes ?



Balanced
Standard mode — a balance of high surface quality and quick print time. Perfect for most prints.



Draft
Quicker "sketch" mode — favors speed over surface quality. Great for multiple iterations.



MinFill
Fastest mode — uses the absolute minimum amount of internal structure. Ideal for large prints that don't need to be durable.

Print Modes are customized sets of recommended print settings. To make modified versions of these Print Modes, please use Custom Print Modes.

Custom Settings
Done

Print Preview

Play Animation

Print Settings

Extruder Type
Smart Extruder+ ▼

Print Mode
Balanced ⋮

Support

Settings affect all models in project

Custom Settings

2.52 am Time Estimate
34m

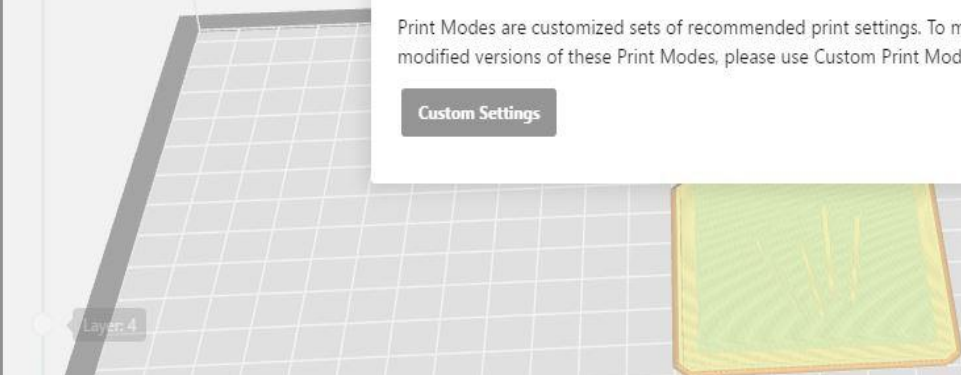

All moves

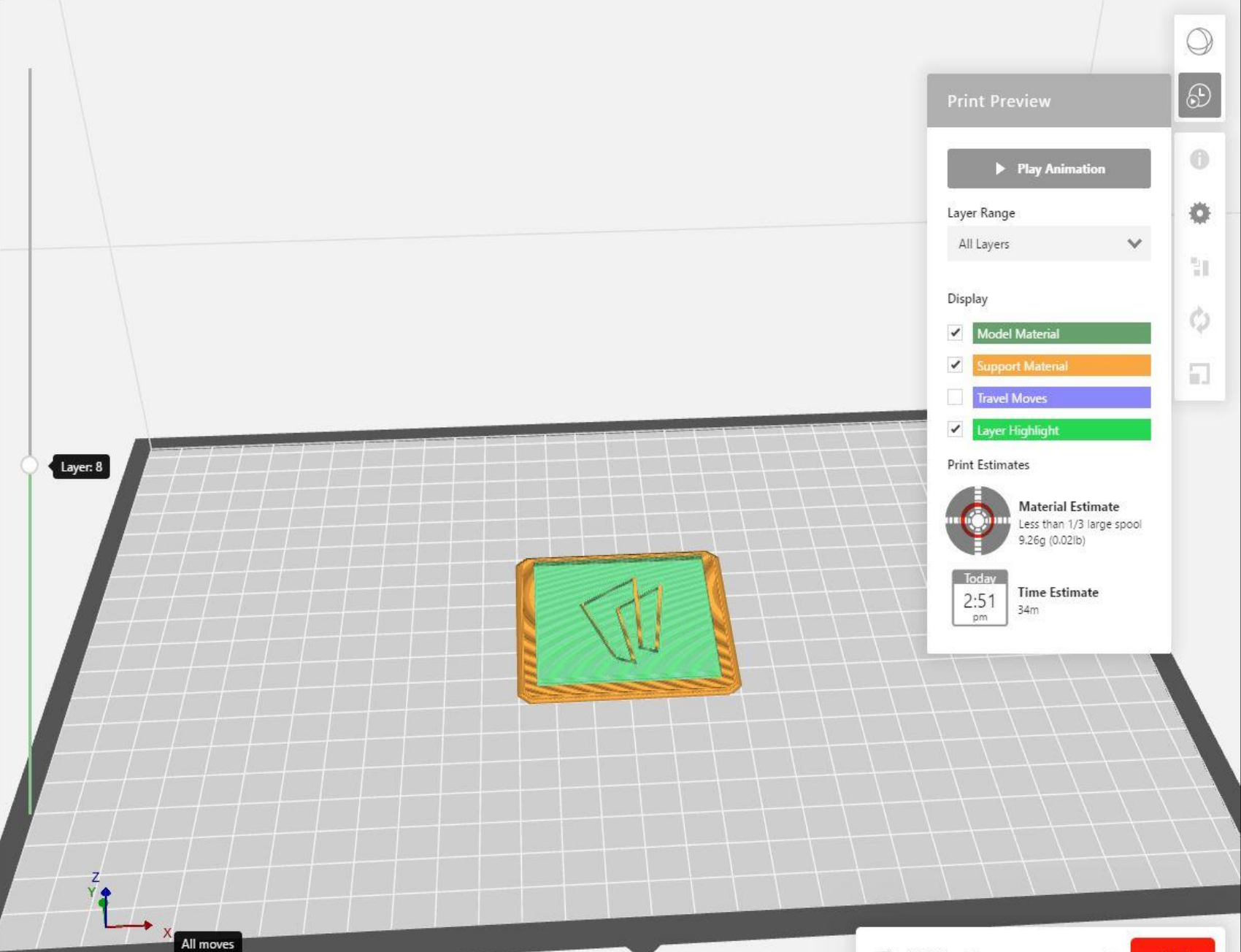

Print Preview

▶ Play Animation

Layer Range
All Layers ▼

Display

- Model Material
- Support Material
- Travel Moves
- Layer Highlight

Print Estimates

 **Material Estimate**
Less than 1/3 large spool
9.26g (0.02lb)

Today
2:51 pm

Time Estimate
34m







Material Estimate
Less than 1/3 large spool
21.06g (0.05lb)

Ready by: ×

Today
4:02
pm

Time Estimate
1h 15m

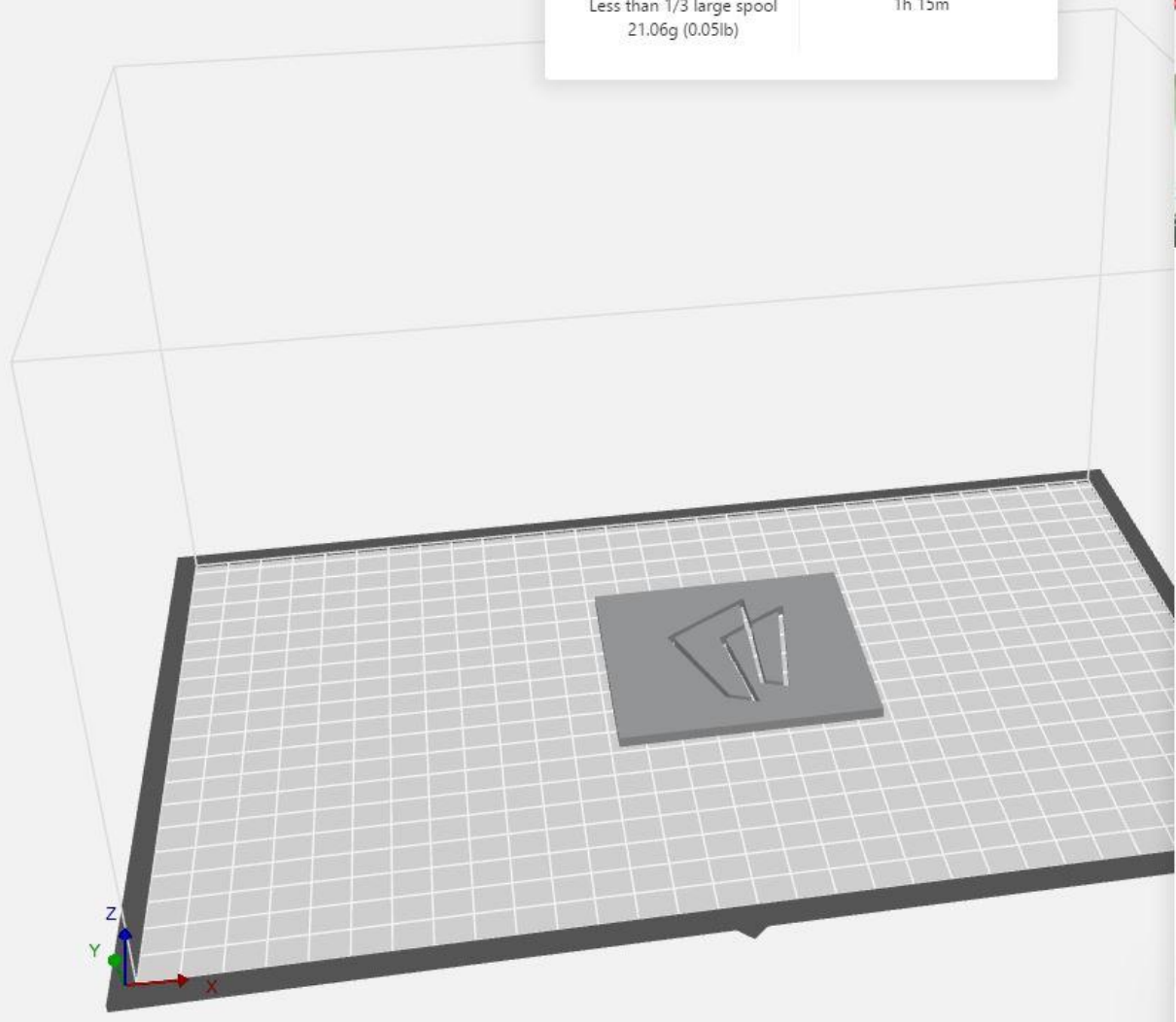





3DP05
Replicator+ Selected ▼



Printing
1-SPL Logo
Current: 210 °C
Elapsed: 0h 0m
Remaining: 1h 14m

1%

 **Pause**  **Cancel**  **Filament**  **Utilities**

 3DP05 • Busy Print



Thank You

Want a copy of this presentation?
Visit www.skokielibrary.info/handouts
where this presentation will be available
for four weeks.

